

Façade
UNIVERS® BRISE-SOLEIL

INSTALLUX
Bâtiment

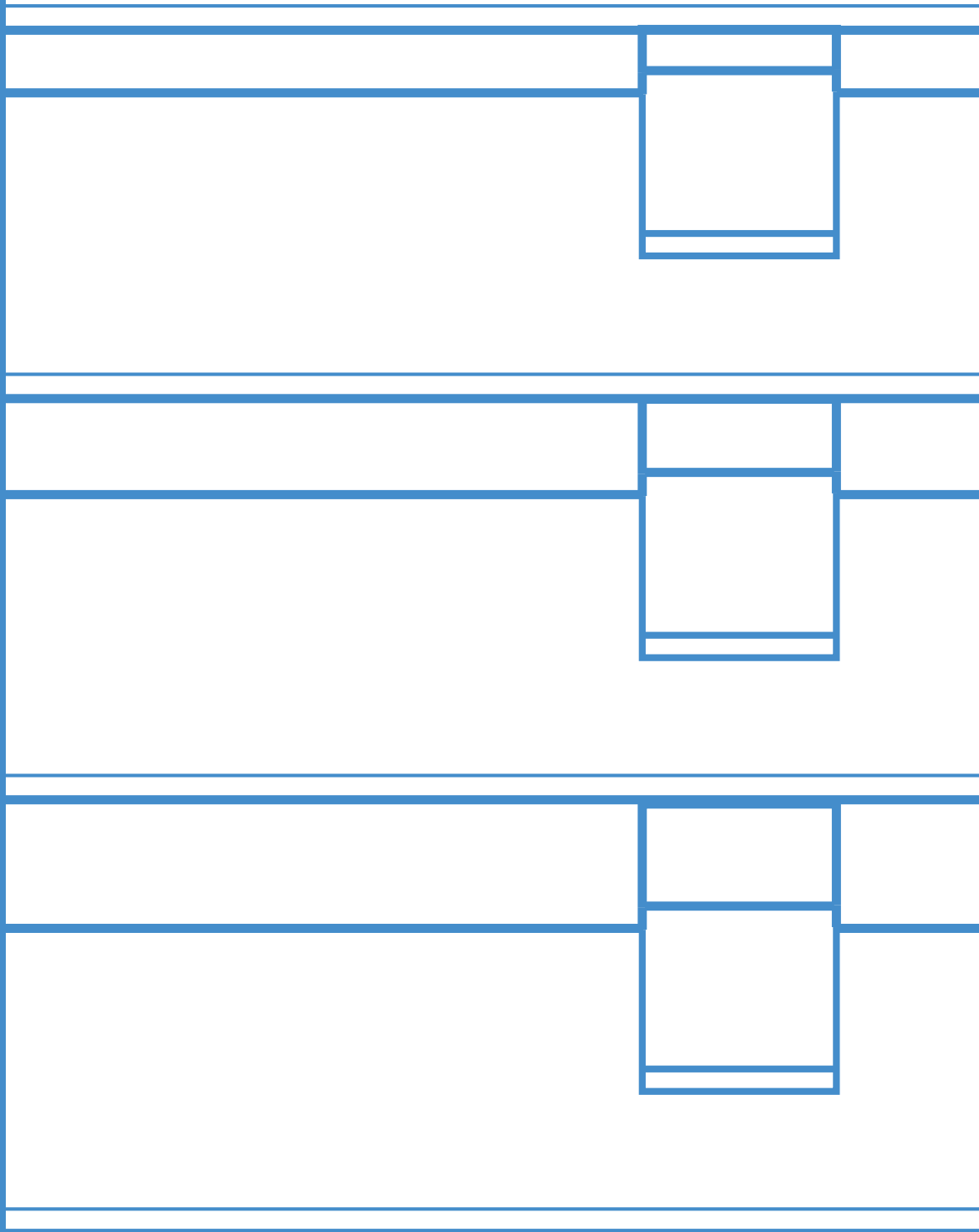

LES FAÇADES
ET LA VERRIÈRE



APPLICATIONS

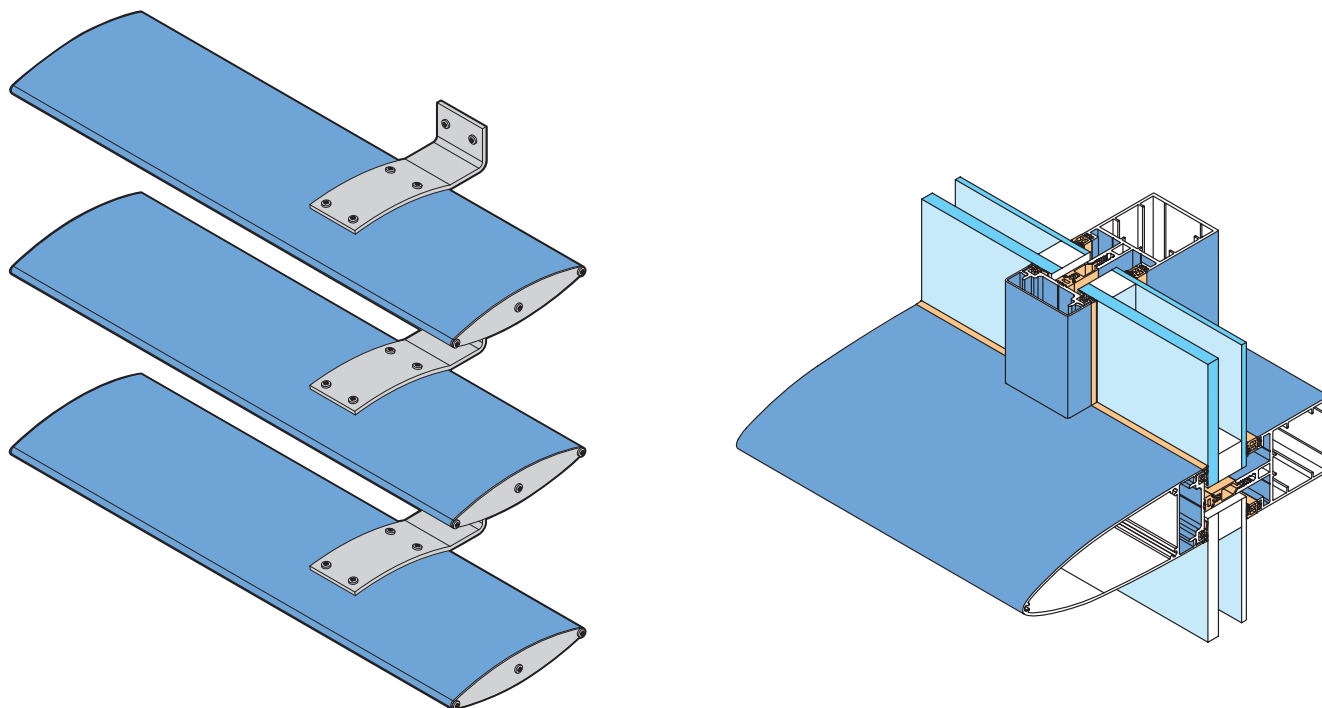

DESCRIPTIF TECHNIQUE

APPLICATION

Brise-soleil à lame fixe pour façade de bâtiment ou adaptable sur la gamme UNIVERS 54.

OSSATURE

Profil de forme elliptique en aluminium extrudé (6060T5).

TRAITEMENT DE SURFACE

Anodisation : classe 20 pour l'argent satiné, classe 15 pour les autres teintes (classe 20 sur demande). Qualité QUALANOD-EWAA-EURAS, selon la norme NFA 91450.

Laquage : Laquage 80 microns, label QUALICOAT / QUALIMARINE

ADAPTATION DANS LA GAMME UNIVERS® 54 - Ech. 1/2

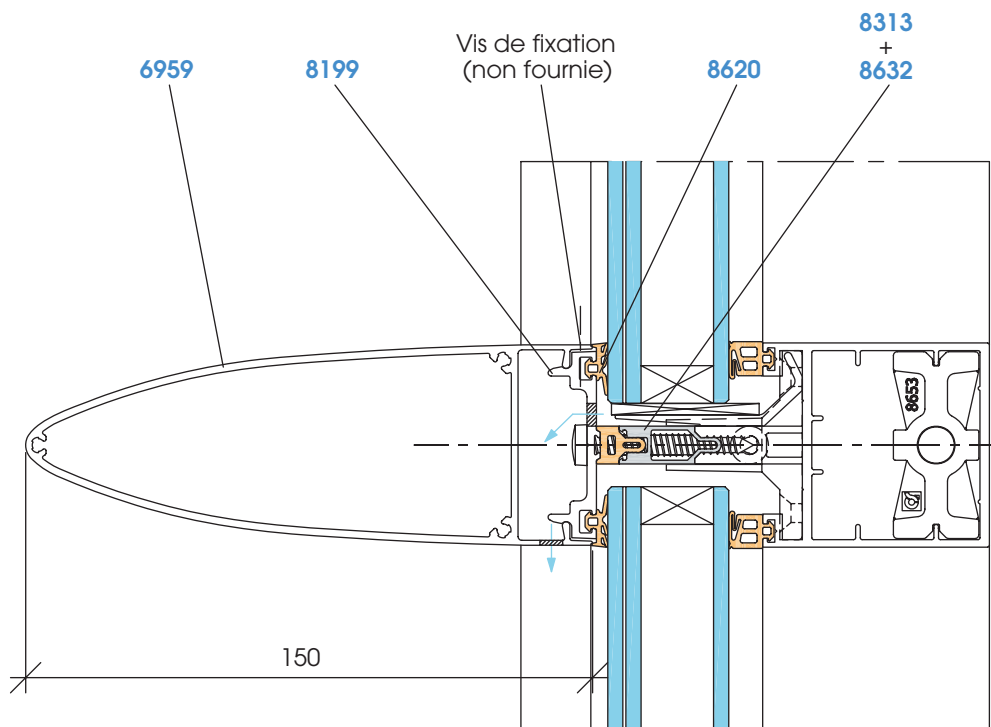
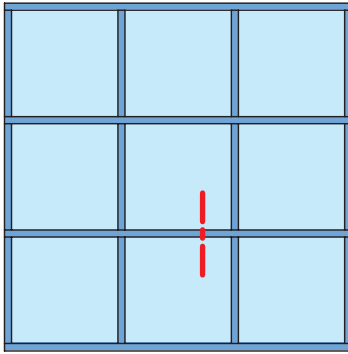

DÉCLINAISON LAMES BRISE-SOLEIL AVEC INTERCALAIRE 6964 - Ech. 1/2

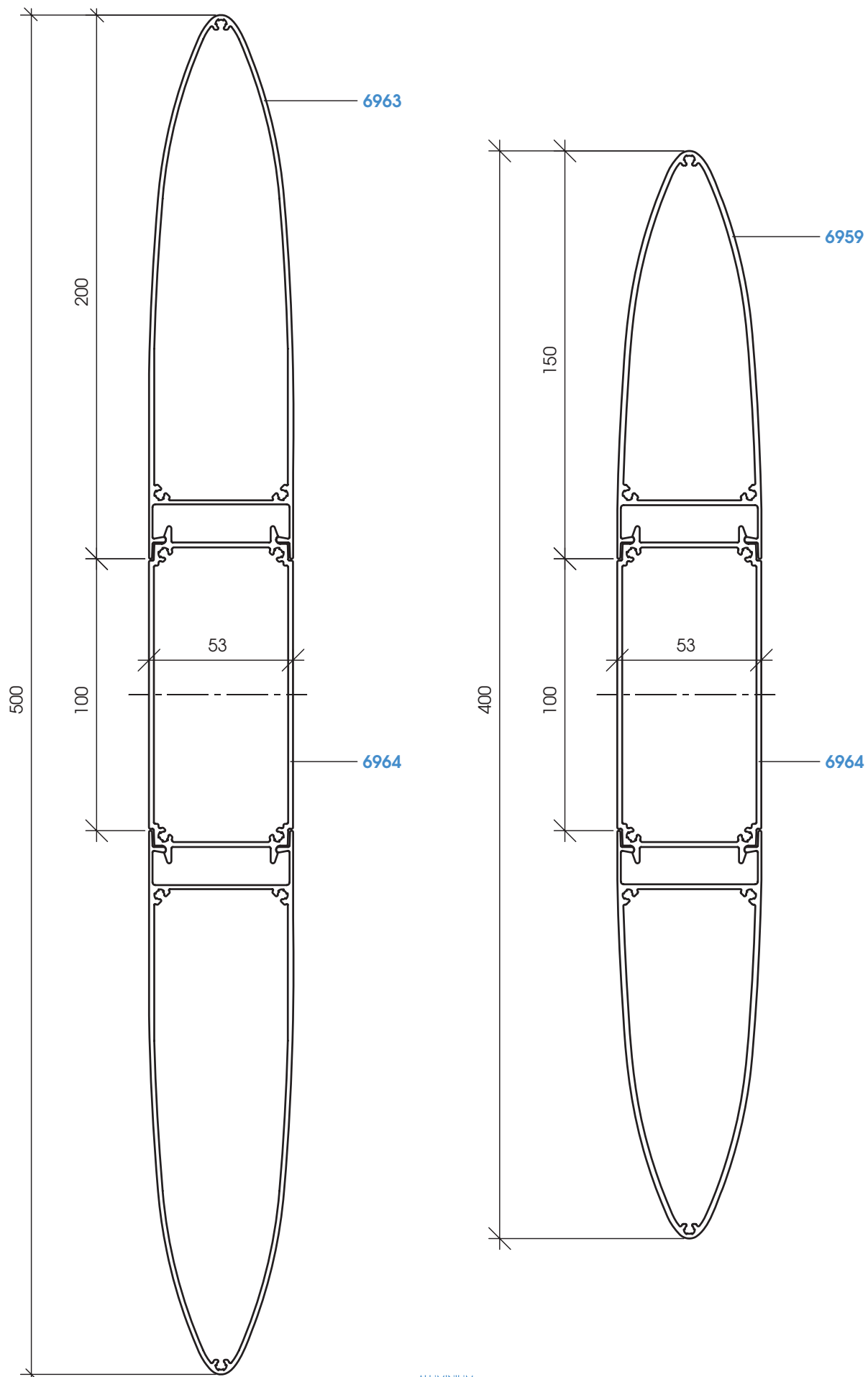

COUPES DE PRINCIPE

DÉCLINAISON LAMES BRISE-SOLEIL AVEC INTERCALAIRE 6975 - Ech. 1/2

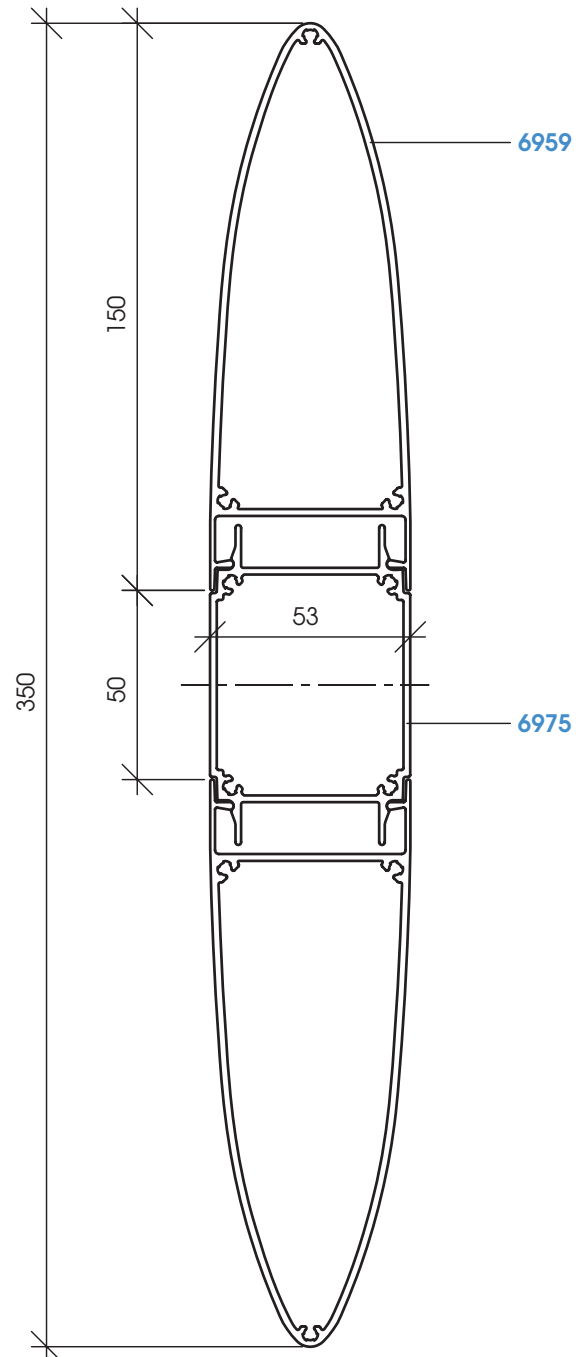
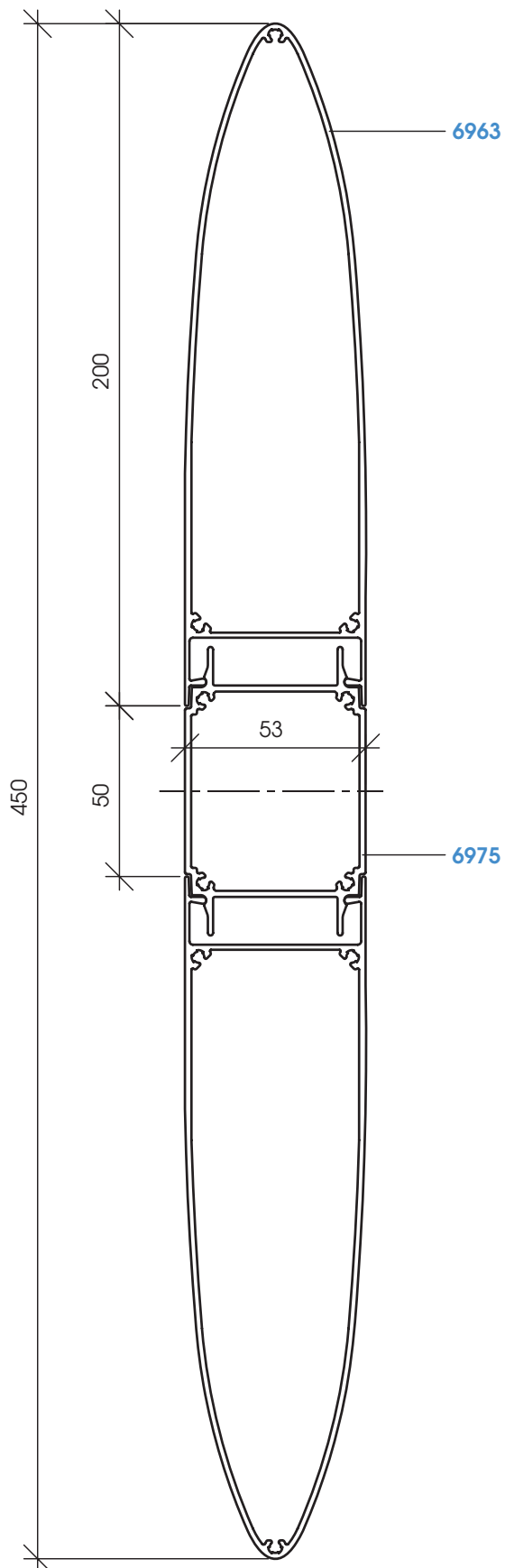

PROFILS - Ech. 1

Référence	Equerre à serfir	Equerre à visser	Equ. maintien	Bloc	Poids(kg)	Pér.Anod(mm)	Ixx(cm4)	Iyy(cm4)
6960					1,700	313	6,5	111,08
6964					1,779	370	32,56	119,7
6975					1,378	312	21,90	35,50

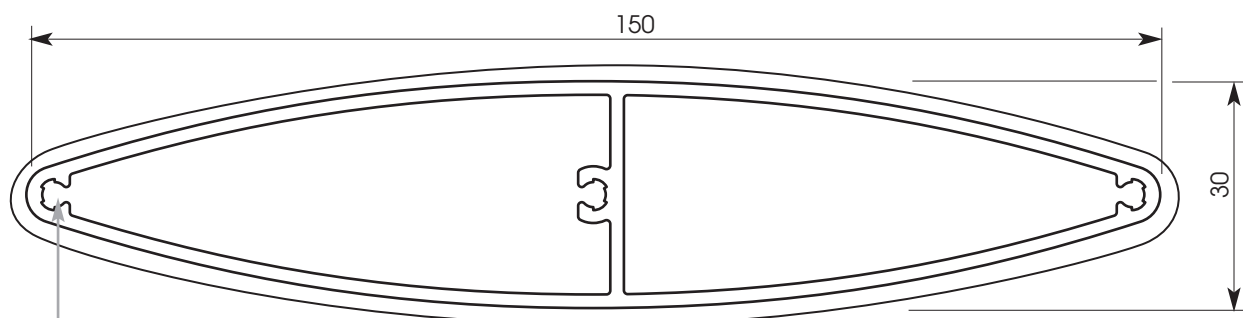

Pour vis
SCR P4

6960

Brise soleil 150 mm

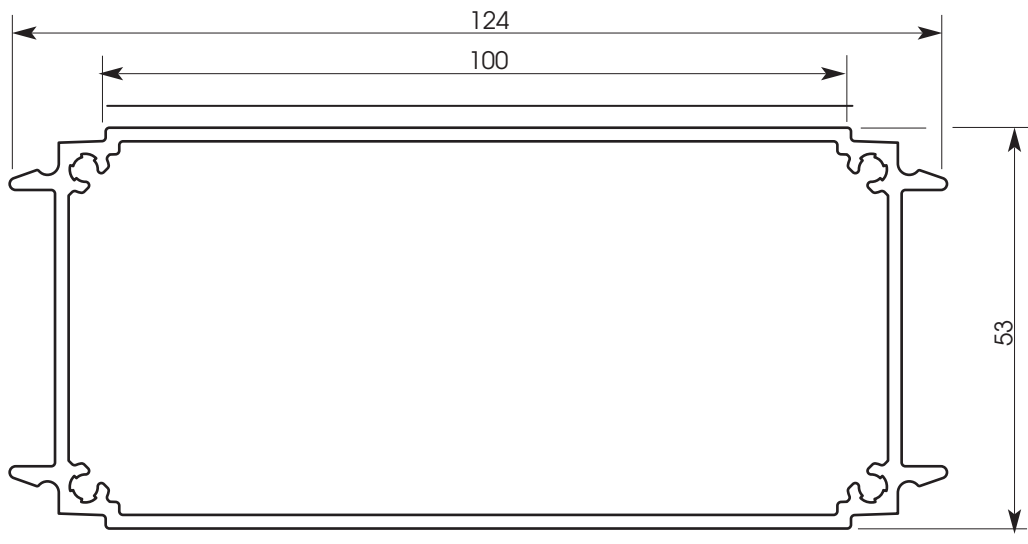

6964

Intercalaire 100 mm

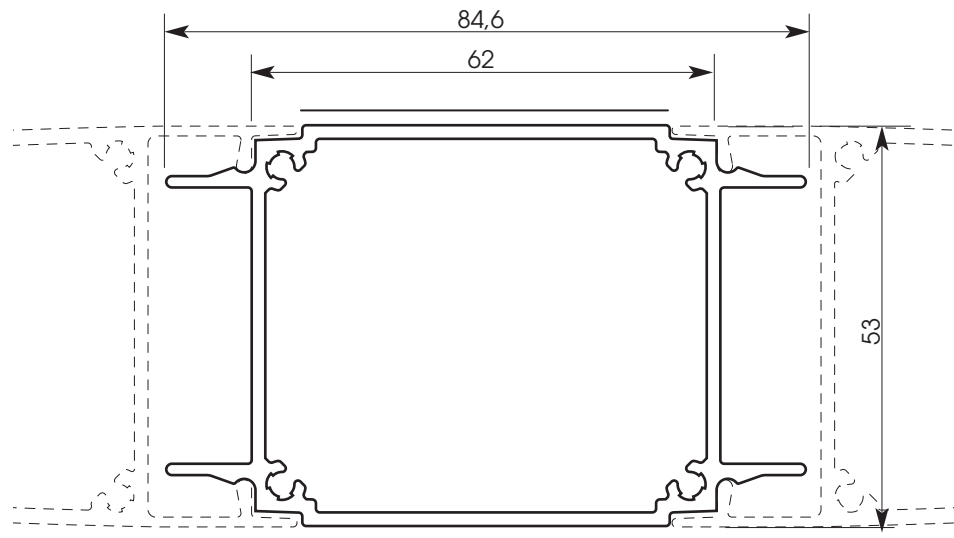

6975

Intercalaire 62 mm

— Faces vues
- - - Faces visibles

PROFILS - Ech. 1

Référence	Equerre à serrer	Equerre à visser	Equ. maintien	Bloc	Poids(kg)	Pér.Anod(mm)	Ixx(cm4)	Iyy(cm4)
6959					1,946	758	147,21	28,79
6963					2,540	522	345,11	42,99

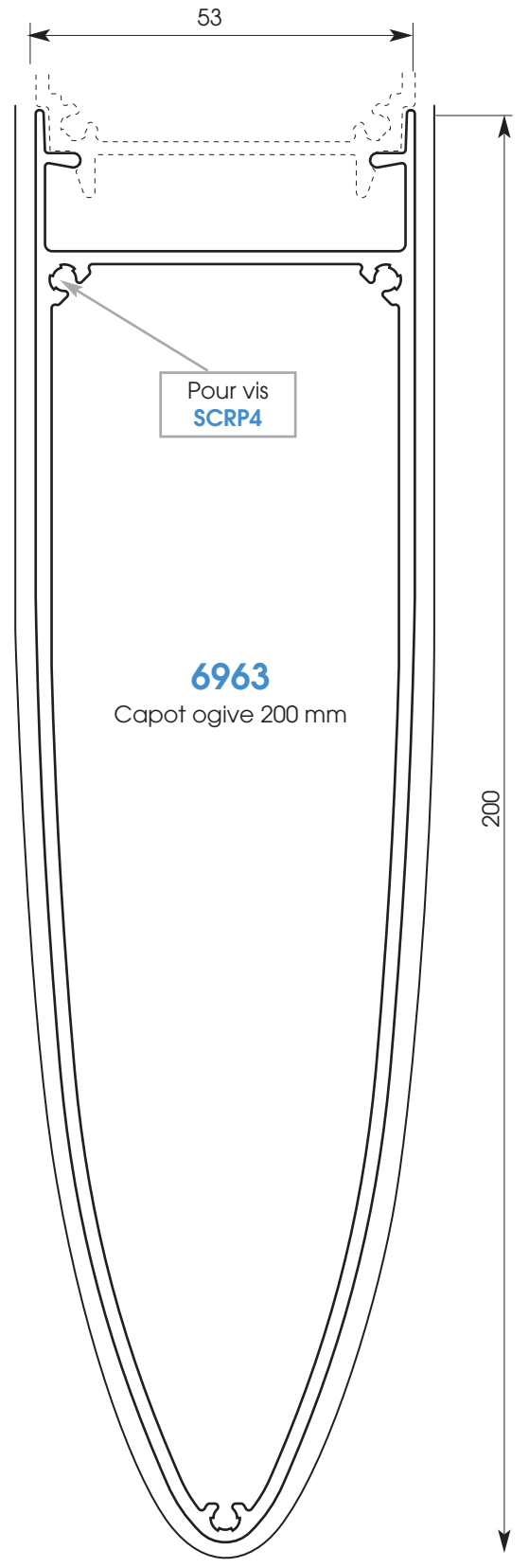
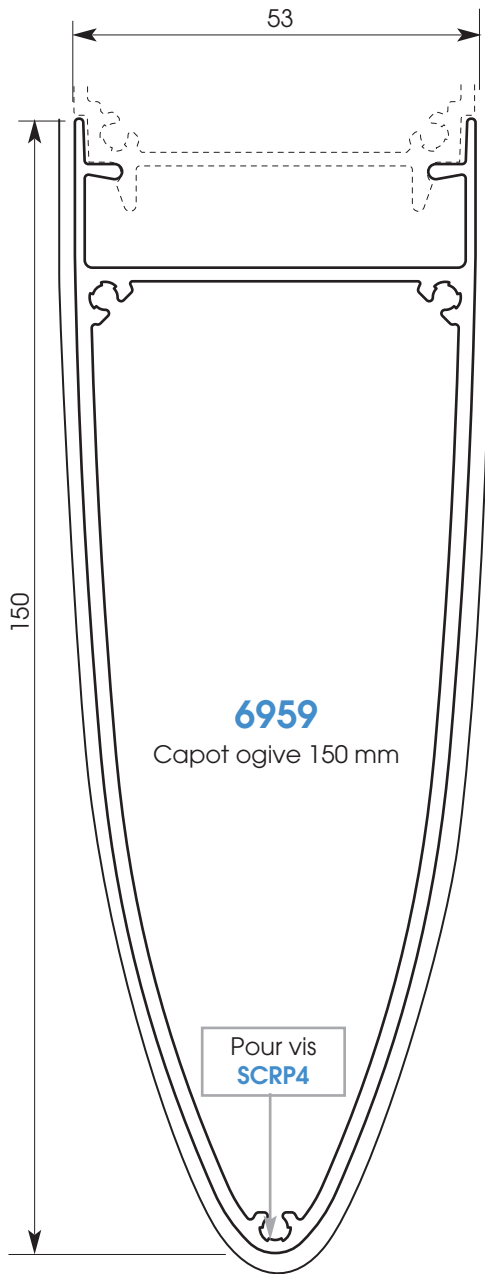

— Faces vues
 - - - Faces visibles

ACCESSOIRES

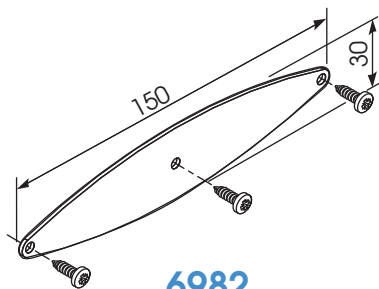

6982
Embout pour profil **6960**
Aluminium

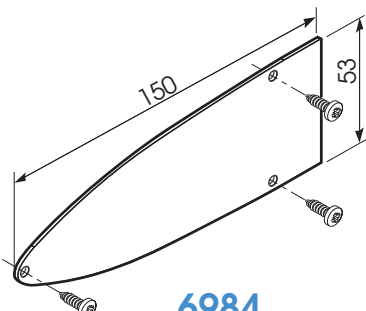

6984
Embout pour profil **6959**
Aluminium

